

RNN and LSTM

Lobacheva Ekaterina

lobacheva.tjulja@gmail.com

Artificial neuron

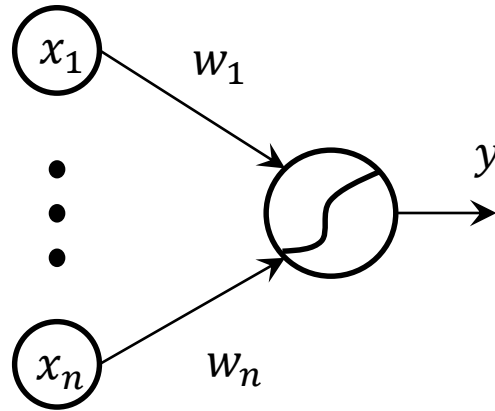

$$net = \sum_{i=1}^n w_i x_i \quad y = f(net)$$

Artificial neural network

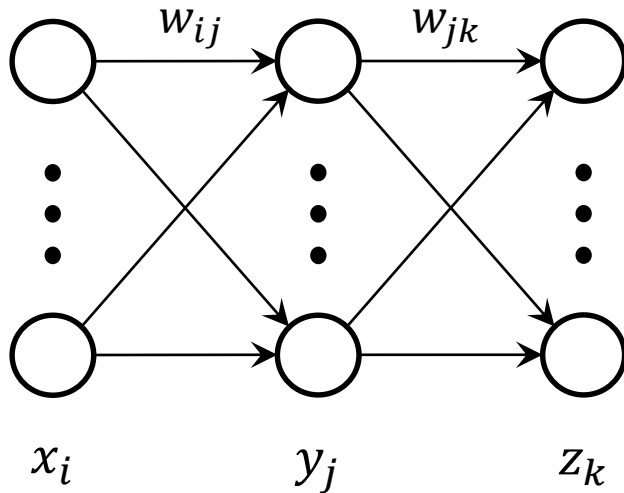

Training samples:

$$(\bar{x}^t, a^t)_{t=1}^T$$

Parameters:

$$\theta = \{w_{ij}, w_{jk}\} \text{ for all } i, j, k$$

Loss function:

$$F(Z(\theta), A) = \sum_{t=1}^T F_t(\bar{z}(t, \theta), a(t)) \rightarrow \min_{\theta}$$

Backpropagation

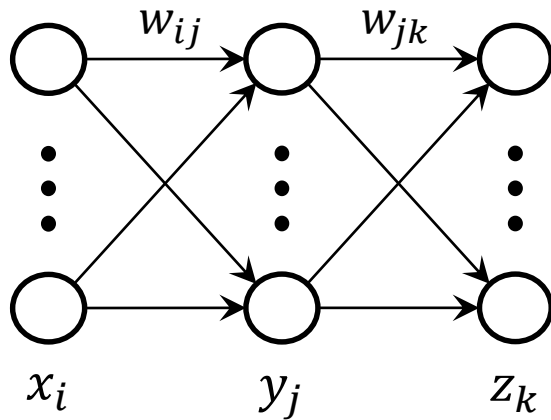

$$net_j = \sum_i w_{ij} x_i \quad y_j = f(net_j)$$

$$net_k = \sum_j w_{jk} y_j \quad z_k = f(net_k)$$

Gradient descent method (usually stochastic)

Forward pass:

$$net_j(t), y_j(t), net_k(t), z_k(t)$$

Backward pass:

$$\frac{\partial F}{\partial w_{ij}}, \frac{\partial F}{\partial w_{jk}}$$

Backpropagation: gradients

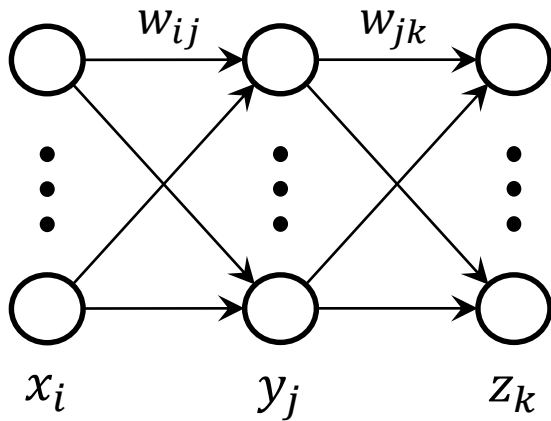

$$\frac{\partial F}{\partial z_k(t)} = \frac{\partial F_t}{\partial z_k(t)}$$

$$\frac{\partial F}{\partial net_k(t)} = \frac{\partial F_t}{\partial z_k(t)} * \frac{\partial z_k(t)}{\partial net_k(t)} = \frac{\partial F_t}{\partial z_k(t)} * f'(net_k(t))$$

$$\frac{\partial F}{\partial w_{jk}} = \sum_{t=1}^T \frac{\partial F_t}{\partial net_k(t)} * \frac{\partial net_k(t)}{\partial w_{jk}} = \sum_{t=1}^T \frac{\partial F_t}{\partial net_k(t)} * y_j(t)$$

$$\frac{\partial F}{\partial y_j(t)} = \sum_k \frac{\partial F_t}{\partial net_k(t)} * \frac{\partial net_k(t)}{\partial y_j(t)} = \sum_k \frac{\partial F_t}{\partial net_k(t)} * w_{jk}$$

$$\frac{\partial F}{\partial net_j(t)} = \frac{\partial F_t}{\partial y_j(t)} * f'(net_j(t))$$

$$\frac{\partial F}{\partial w_{ij}} = \sum_{t=1}^T \frac{\partial F_t}{\partial net_j(t)} * \frac{\partial net_j(t)}{\partial w_{ij}} = \sum_{t=1}^T \frac{\partial F_t}{\partial net_j(t)} * x_i(t)$$

Recurrent neural network

What if we want to capture dependencies between x_t and $a(t + \tau)$?

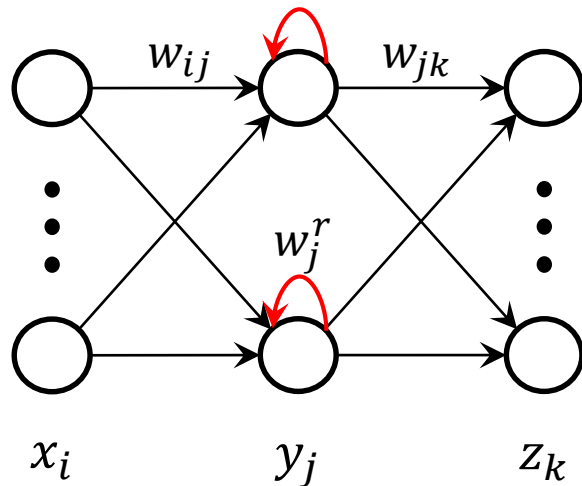

$$y_j(t) = f \left(\sum w_{ij} x_i(t) + w_j^r y_j(t - 1) \right)$$

through time

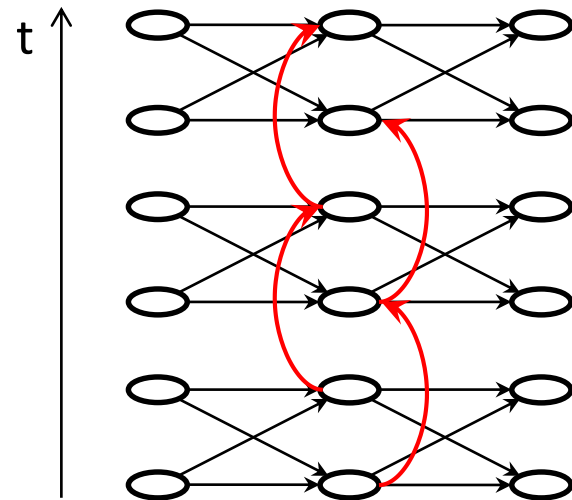
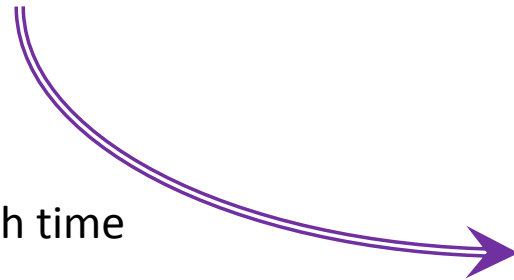

Recurrent neural network

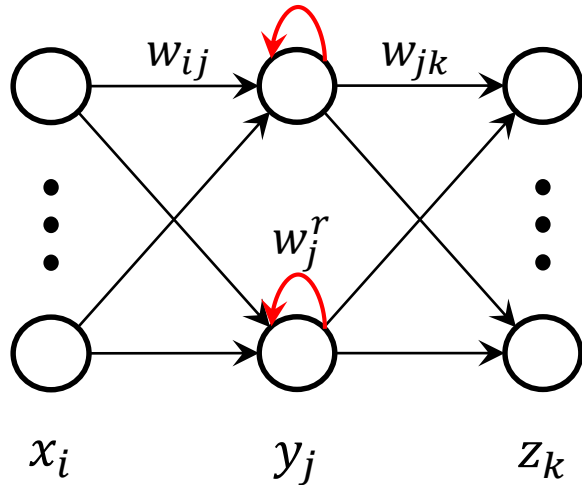

Training sample - sequence:

$$(\bar{x}^t, a^t)_{t=1}^T$$

Parameters:

$$\theta = \{w_{ij}, w_{jk}, w_j^r\} \text{ for all } i, j, k$$

Loss function:

$$F(Z(\theta), A) = \sum_{t=1}^T F_t(\bar{z}(t, \theta), a(t)) \xrightarrow{\theta} \min$$

Backpropagation through time

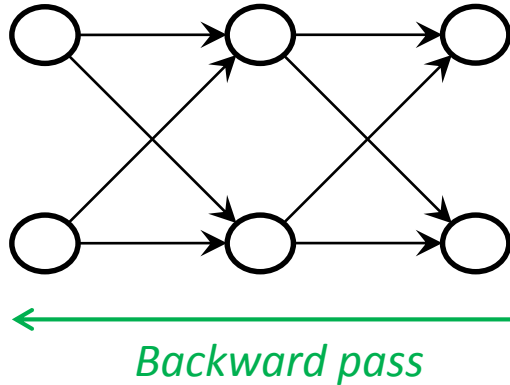

Trough layers and time

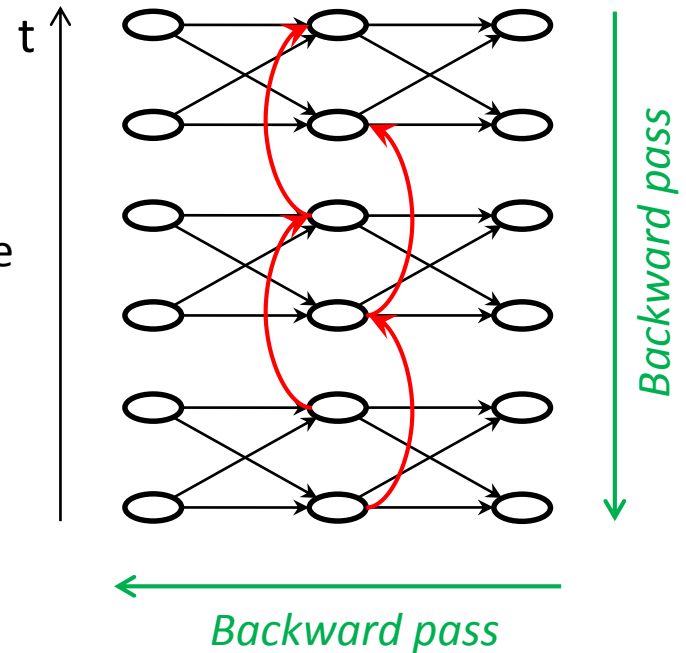

$$\frac{\partial F}{\partial y_j(t)} = \frac{\partial F_t}{\partial y_j(t)}$$

$$\frac{\partial F}{\partial y_j(t)} = \sum_{\tau=t}^T \frac{\partial F_{\tau}}{\partial y_j(t)}$$

Backpropagation through time

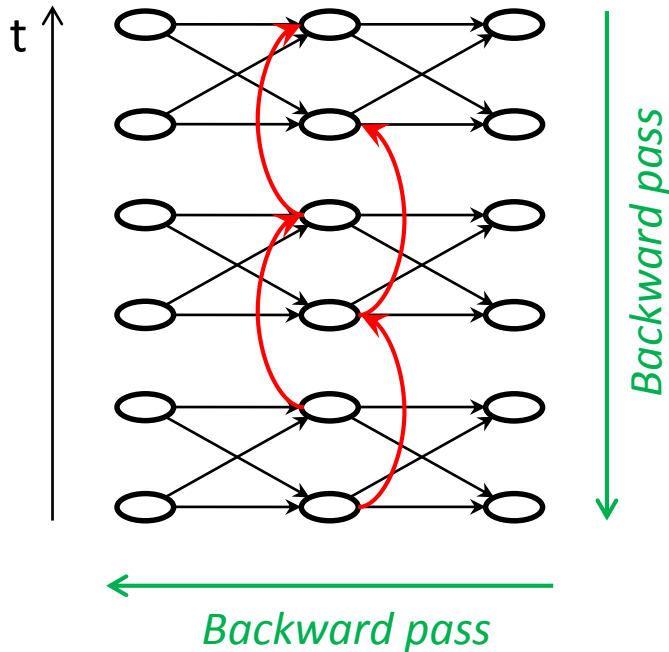

Trough layers and time

• • •

$$\frac{\partial F}{\partial y_j(t)} = \sum_{\tau=t}^T \frac{\partial F_{\tau}}{\partial y_j(t)}$$

$$\frac{\partial F_t}{\partial y_j(t)} = \sum_k \frac{\partial F_t}{\partial net_k(t)} * w_{jk}$$

$$\frac{\partial F_{\tau}}{\partial y_j(t)} = \frac{\partial F_{\tau}}{\partial y_j(\tau)} \prod_{l=t}^{\tau-1} \frac{\partial y_j(l+1)}{\partial y_j(l)} = \frac{\partial F_{\tau}}{\partial y_j(\tau)} \prod_{l=t}^{\tau-1} \boxed{f'(net_j(l+1)) w_j^r}$$

exploding or vanishing gradients

no long-range dependencies

Long short term memory

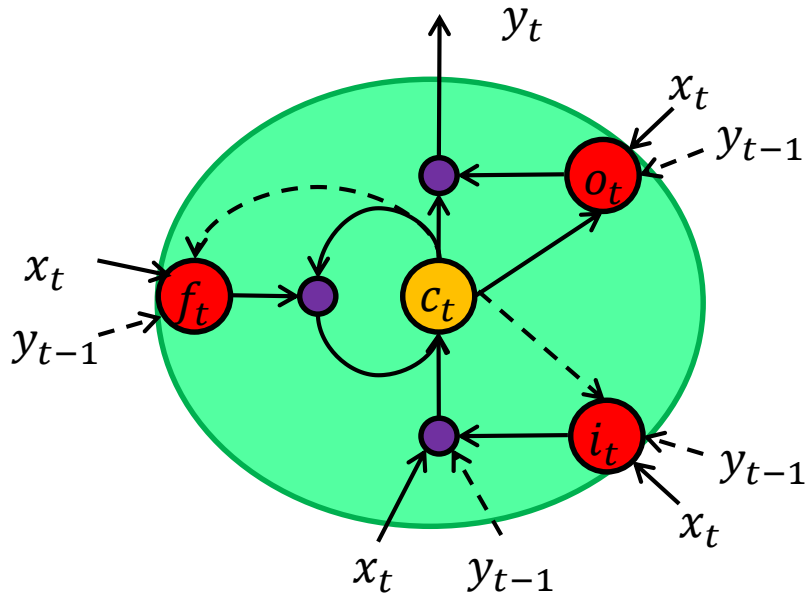

i_t, f_t, o_t - gates from 0 to 1

c_t - memory

x_t - input, y_t - output

$$i_t = \sigma(w_{ix}x_t + w_{ic}c_{t-1} + w_{iy}y_{t-1} + b_i)$$

$$f_t = \sigma(w_{fx}x_t + w_{fc}c_{t-1} + w_{fy}y_{t-1} + b_f)$$

$$o_t = \sigma(w_{ox}x_t + w_{oc}c_t + w_{oy}y_{t-1} + b_o)$$

$$c_t = f_t c_{t-1} + i_t * \tanh(w_{cx}x_t + w_{cy}y_{t-1})$$

$$y_t = o_t * \tanh(c_t)$$

Long short term memory

Captures inf.

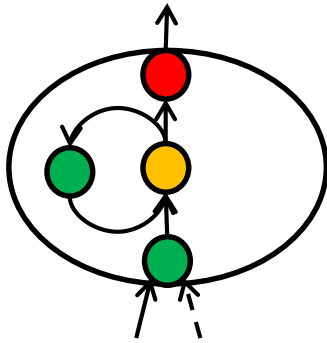

Keeps inf.

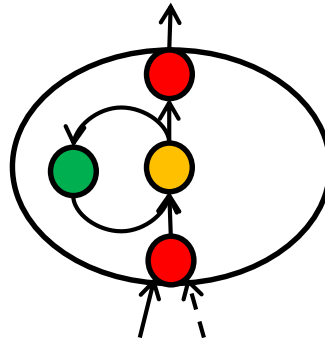

Releases inf.

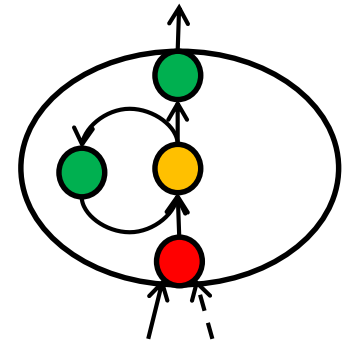

Erases inf.

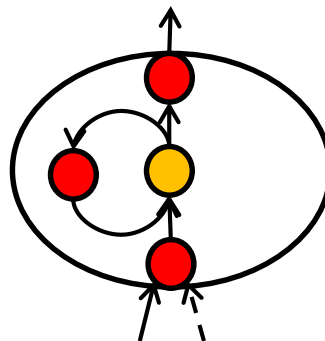

= RNN

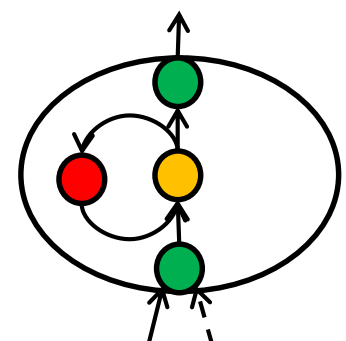

 - gate is close

 - gate is open

RNN and LSTM examples

Architecture 1

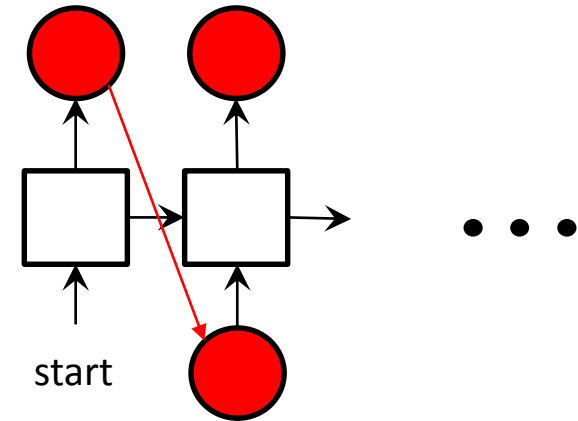
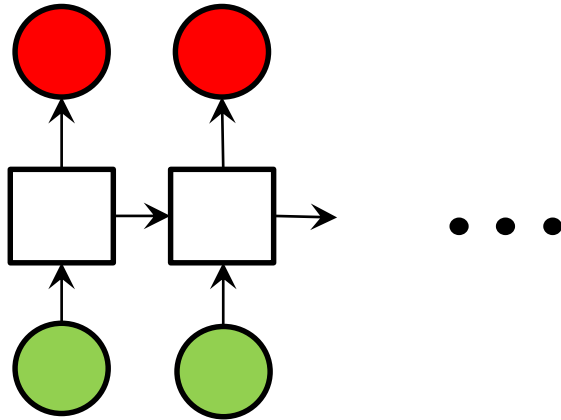

- Element-wise classification of a sequence
- Element-wise translation of a sequence

- Sequence generation

Text generation

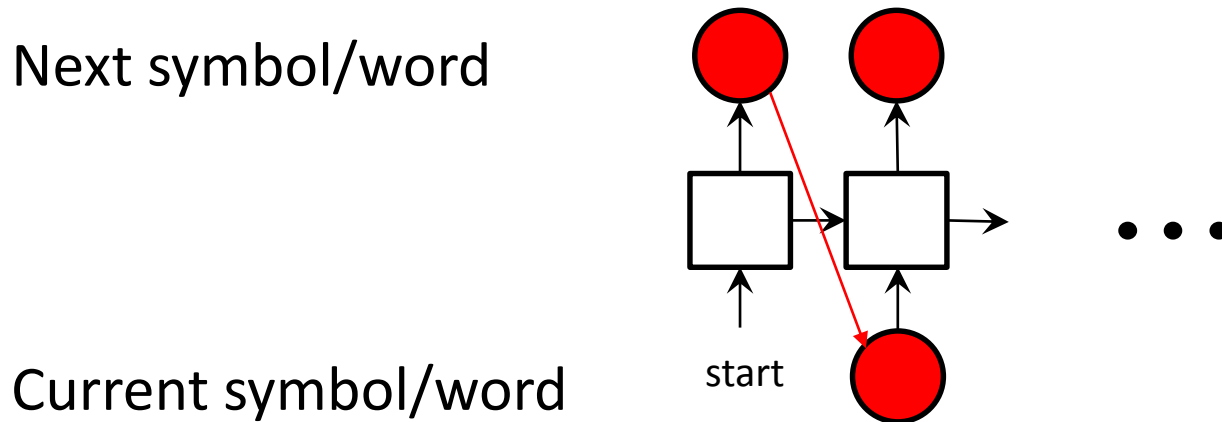

[Demo](#) (character-wise, MRNN)

Text generation:

Example results of the word-wise RNN

YOU WOULD NOT SUFFER WHAT HE WAS PROMOTING IN A NATION IN THE CENTRAL INDUSTRY
AND CAME TO IRAN AND HE DID AND HE HAVE PROMISED THEY'LL BE ANNOUNCING HE'S FREE
THE PEACE PROCESS

SHARON STONE SAID THAT WAS THE INFORMATION UNDER SURVEILLING SEPARATION SQUADS

PEOPLE KEPT INFORMED OF WHAT DID THEY SAY WAS THAT %HESITATION

WELL I'M ACTUALLY A DANGER TO THE COUNTRY THE FEAR THE PROSECUTION WILL LIKELY MOVE

WELL THAT DOES NOT MAKE SENSE

THE WHITE HOUSE ANNOUNCED YESTERDAY THAT THE CLINTON ADMINISTRATION ARRESTED THIS
PRESIDENT OFTEN CONSPICUOUSLY RELIEVED LAST DECEMBER AND AS A MEMBER OF THE SPECIAL
COMMITTEE

THE GUARDIAN EXPRESSED ALL DESIRE TO LET START THE INVESTIGATION

IN NORTH KOREA THIS IS A JOKE

Handwriting generation:

handwriting -> handwriting

Next pen position (we predict parameters):

x_1, x_2 - mixture of bivariate Gaussians

x_3 - Bernoulli distribution

Current pen position:

x_1, x_2 - pen offset

x_3 - is it end of the stroke

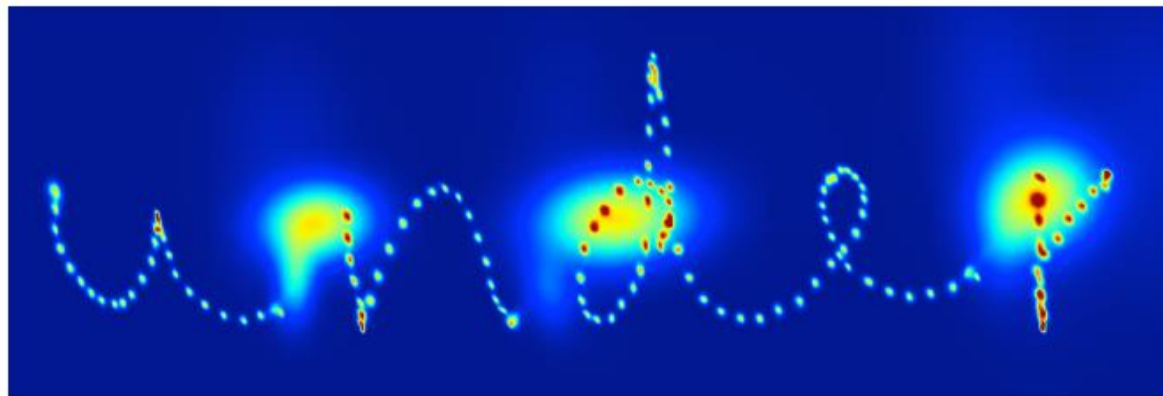
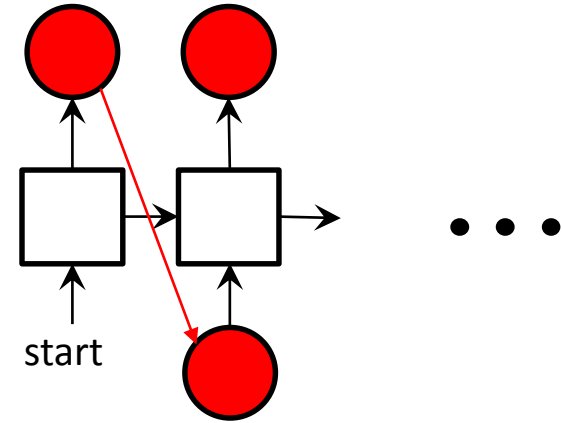

Handwriting generation:

example

when my under you cage there. it

pegged and the. 'bepestures the the

Anaime Cenele of high creditra'
see Bony a. the correction is

purely mistaker so learned

boxes & cold mine's wine cases

heist. Y Ceehs the gayer in

style satet Bony In doing Te a

Handwriting synthesis:

text -> handwriting

Next pen position

Current pen position

Which letter we write now

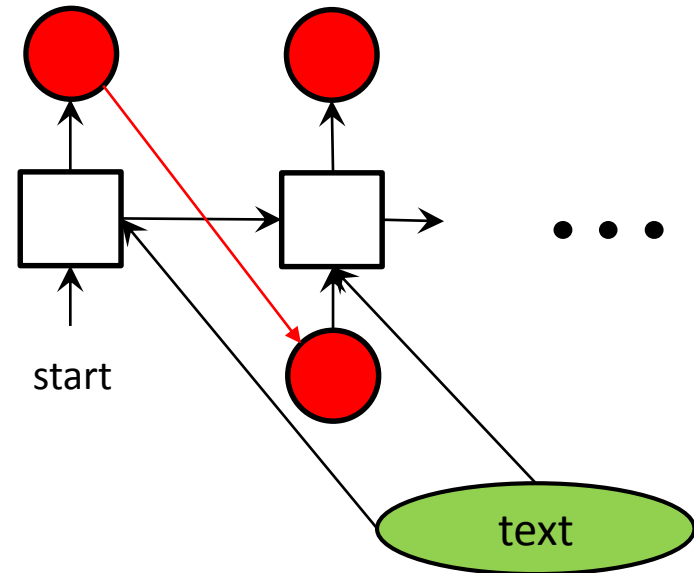

[Demo](#)

Handwriting synthesis:

biased sampling

0 when the samples are biased

0.1 towards more probable sequences

0.5 they get easier to read

2 but less diverse

5 until they all look

10 exactly the same

10 exactly the same

bias

Handwriting synthesis:

primed sampling

Take the breath away when they are

when the network is primed
with a real sequence

the samples mimic

the writer's style

Handwriting synthesis:

primed and biased sampling

Take the breath away where they are

when the network is primed
and biased, it writes
in a cleaned up version
of the original style

Architecture 2

- Sequence classification

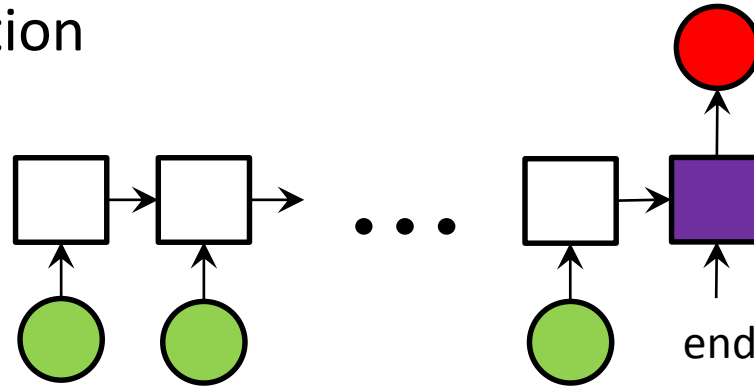

- Sequence translation

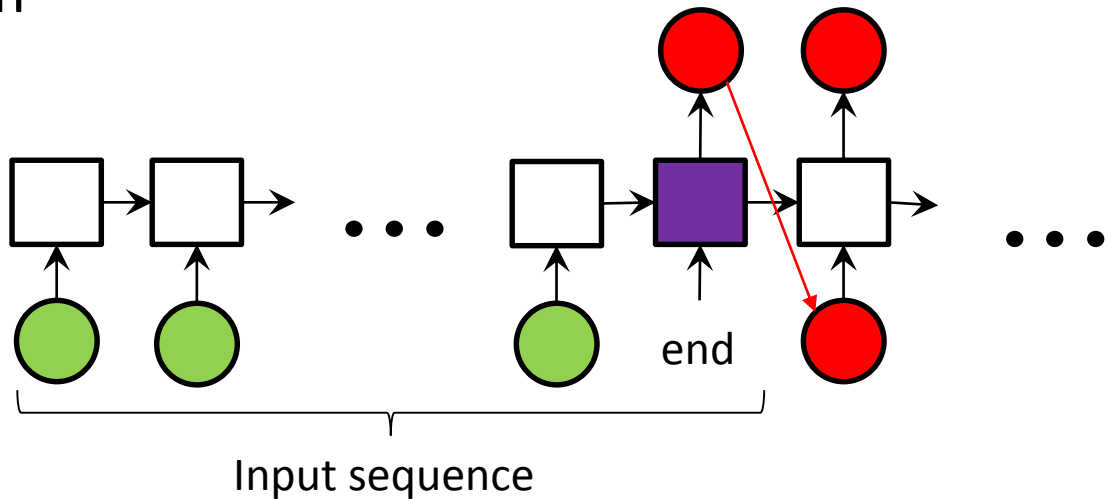

Language translation

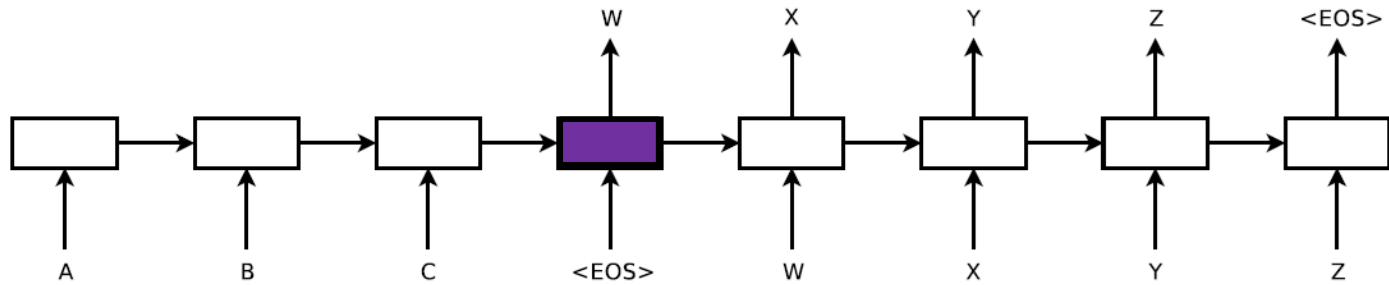

[Demo](#) with bidirectional RNN

Architecture 3

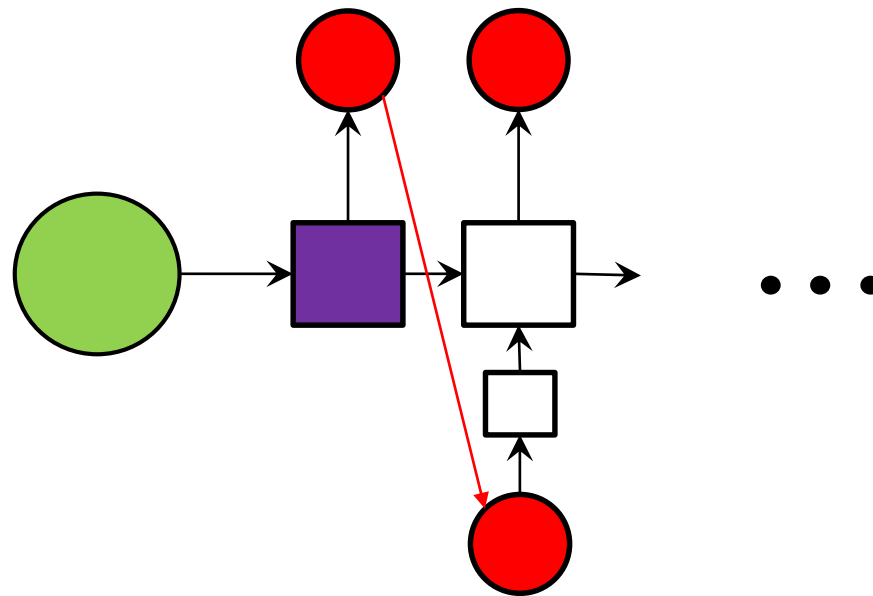
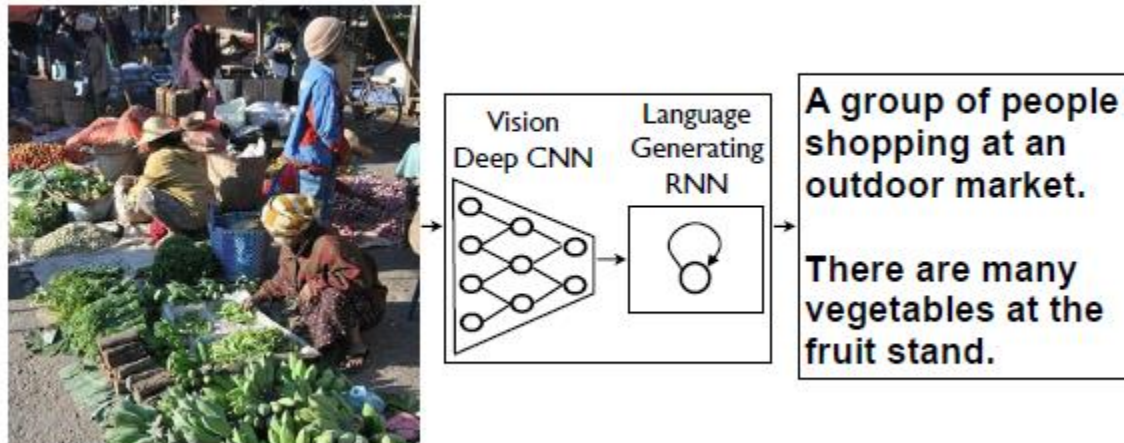

Image Caption Generation



[Demo](#) (images)

[Demo](#) (top images for test texts)

[Demo](#) (more sophisticated model)

Reference

Theory

Hochreiter, Sepp, and Jurgen Schmidhuber. [Long short-term memory](#) // Neural computation 9.8: 1735-1780. 1997.

F. A. Gers. [Long Short-Term Memory in Recurrent Neural Networks](#) // PhD thesis, Department of Computer Science, Swiss Federal Institute of Technology, Lausanne, EPFL, Switzerland, 2001.

J. Schmidhuber. [Long Short-Term Memory: Tutorial on LSTM Recurrent Networks](#).

J. Schmidhuber. [Deep Learning in Neural Networks: An Overview](#).

Klaus Greff, Rupesh Kumar Srivastava, Jan Koutník, Bas R. Steunebrink, Jürgen Schmidhuber. [LSTM: A Search Space Odyssey](#).

Libraries

Different deep architectures -

[torch](#)

[pybrain](#)

[theano](#) (see [tutorials](#))

RNN and LSTM library by Graves - [rnnlib](#)

RNN Language Models by Mikolov - [rnnlm](#)

Reference: examples

Sequence generation

- **Character-wise text generation with Multiplicative RNN**

Ilya Sutskever, James Martens, and Geoffrey Hinton. [Generating Text with Recurrent Neural Networks](#) // ICML 2011.

[demo](#), [slides](#)

- **Word-wise text generation with RNN (RNN vs n-grams)**

Mikolov Tomáš, Karafiát Martin, Burget Lukáš, Ěernocký Jan, Khudanpur Sanjeev. [Recurrent neural network based language model](#). // Proceedings of the 11th Annual Conference of the International Speech Communication Association (INTERSPEECH 2010).

Mikolov Tomáš. [Statistical Language Models based on Neural Networks](#) // PhD thesis, Brno University of Technology, 2012.

[lib+demo](#)

- **Both character and word-wise text generation + handwritten generation + handwritten synthesis (all with LSTM)**

A. Graves. [Generating Sequences With Recurrent Neural Networks](#).

[slides](#), [handwritten synthesis demo](#)

Reference: examples

Sequence translation

Ilya Sutskever, Oriol Vinyals, Quoc Le. [Sequence to Sequence Learning with Neural Networks](#) // NIPS 2014

K. Cho, B. van Merriënboer, C. Gulcehre, D. Bahdanau, F. Bougares, H. Schwenk, Y. Bengio. [Learning Phrase Representations using RNN Encoder-Decoder for Statistical Machine Translation](#) // EMNLP 2014.

[demo](#)

Image Caption Generation

O. Vinyals, A. Toshev, S. Bengio, and D. Erhan. [Show and tell: A neural image caption generator](#) // CVPR, 2015.

Andrej Karpathy, Li Fei-Fei. [Deep Visual-Semantic Alignments for Generating Image Descriptions](#) // CVPR, 2015.

[demo](#) (images), [demo](#) (top images for test texts)

Ryan Kiros, Ruslan Salakhutdinov, Richard Zemel. [Unifying Visual-Semantic Embeddings with Multimodal Neural Language Models](#) // ACL, 2015

[demo](#)